

CLIP INSTALLATION

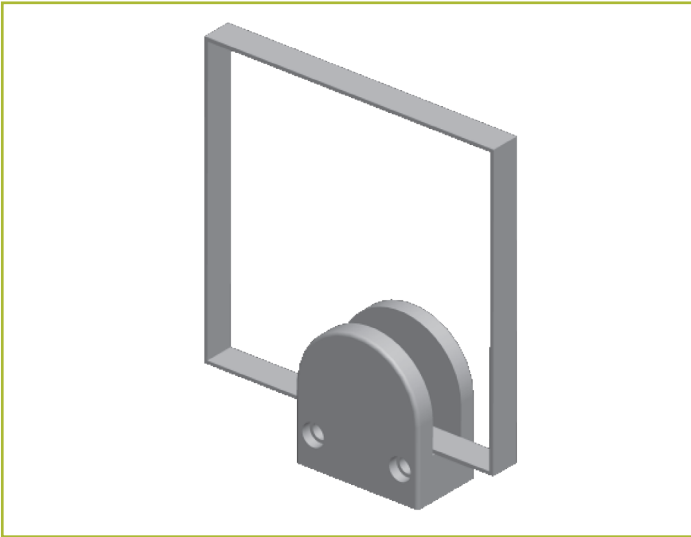

Figure 1

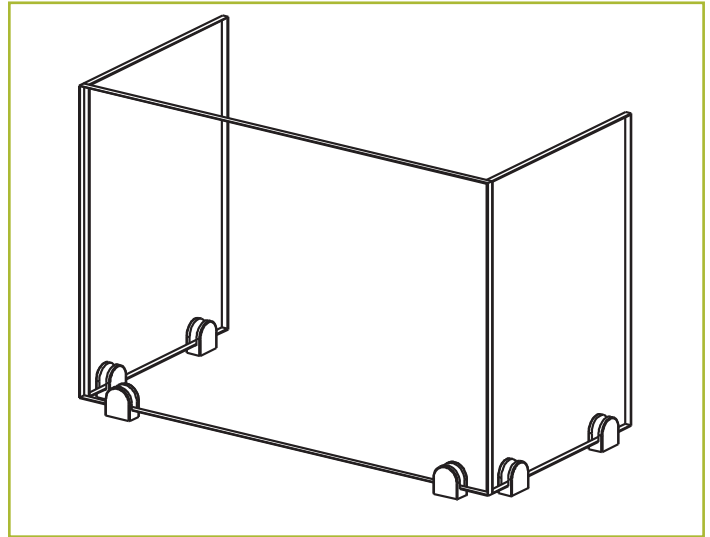

Figure 2

Rendering of Glass Panel in Clip

CLIP ASSEMBLY AND PARTS

- Using an allen/hex wrench, remove the two side screws (Figure 1).
- Discard the plastic shipping brace between the two clips.
- Keep the rubber inserts that are attached to the clips. They are needed to properly secure the glass.
- You will need to provide your own screws to secure to the countertop (see chart below).

PREPPING COUNTER SURFACE

- Clean countertop and food guard where they will meet with isopropyl alcohol. Make sure all surfaces are clean and free of dust.

CLIP AND GLASS INSTALLATION

BSI recommends that two people install ClearView guards.

- Position clips on glass in desired location and secure to glass (Figure 2).
- BSI recommends placing a glass clip 4" in from each end of the glass panel edge (Figure 2). For panels longer than 48", add a third clip in the middle of the span for support
- Place clipped glass in location on counter. While carefully balancing the glass, mark the glass position with tape on the counter.
- Carefully set glass aside and remove clips.
- In the taped off areas, pre-drill the screw holes.
- Screw half of the clip securely to the counter.
- Screw the other half of the clip into position, but do not tighten entirely.
- Carefully align glass panel(s) between the clips and tighten screw completely.

Counter Material	Recommended Hole/Screw (screw length based of counter thickness)
Stainless Steel Top	10-32 machine screw drilled and tapped into the top
Solid Surface	Clearance hole through the solid surface with a #10 wood screw into the subtop
Quartz/Stone	Clearance hole through the top with a #10 wood screw into the subtop

SILICONE INSTALLATION

For installations using silicone that adheres to the countertop, contact BSI at 800.662.9595 for details.

CUSTOM CLAMP INSTALLATION

STRAIGHT GLASS PANELS

The maximum length of a 3/8" glass panel is 66". For straight glass spans, the clamp is screwed directly to the counter. An optional stainless steel screw cover can be siliconed to the clamp, hiding the screw head (Figure 3).

Using silicone in the clamp channel, secure the glass panel (Figure 4).

For straight spans exceeding 66", panels are shipped in multiple pieces. After attaching the clamp to the counter, use silicone to secure the glass panel both in the channel and to the glass next to it (Figure 5).

CURVED OR BENT GLASS PANELS

Depending on lengths, glass panels may arrive prebonded or as separate sections to be siliconed in the field. Each section is screwed to the counter. Glass panels are then siliconed in the channel and to each other if not already bonded.

Exploded View (bracket ships fully assembled)

Figure 3

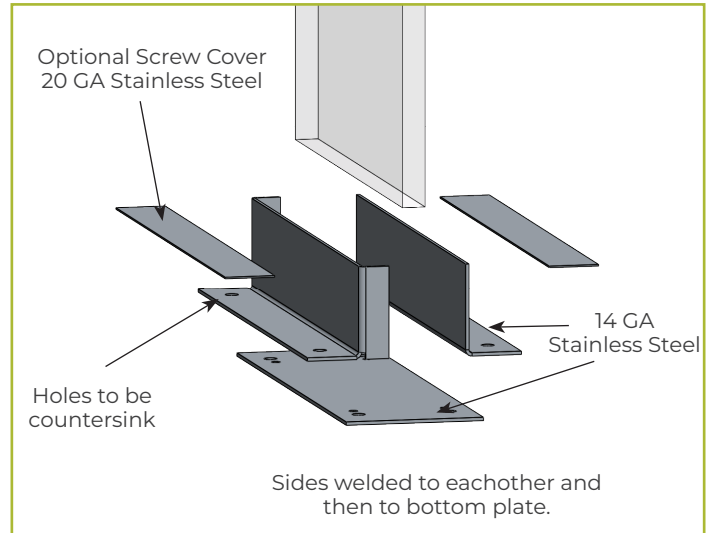

Assembled Installation (shown with screw covers)

Figure 4

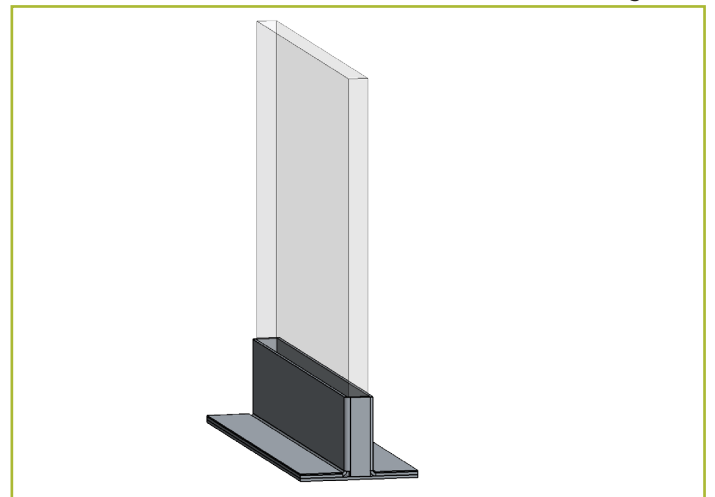

L-Shaped Layout Sample

Figure 5

